

## INSTALLATION OF NOZZLES

The optimum height for the Nozzle above the floor surface of the stall is 9 to 12 feet. Use any structure such as a rafters, trusses, sub-floor, or electrical conduit to fasten tubing over the center of each stall. Figures below show the three ways to attach Nozzles. If a wooden structure or conduit is not available, then it is necessary to string plastic coated cable. Using plastic cable ties, mount Nozzles over the center of each stall.

Run the Tubing through out the barn. Basically, run the Tubing over the stalls and back to the Master Unit. Pages 8 and 9 show different barn configurations and are discussed under each configuration.

**NOTE:** Barns with more than 25 Nozzles in one building should use 3/8" Tubing from the Master Unit to the main loop. See pages 15 and 16 for more information

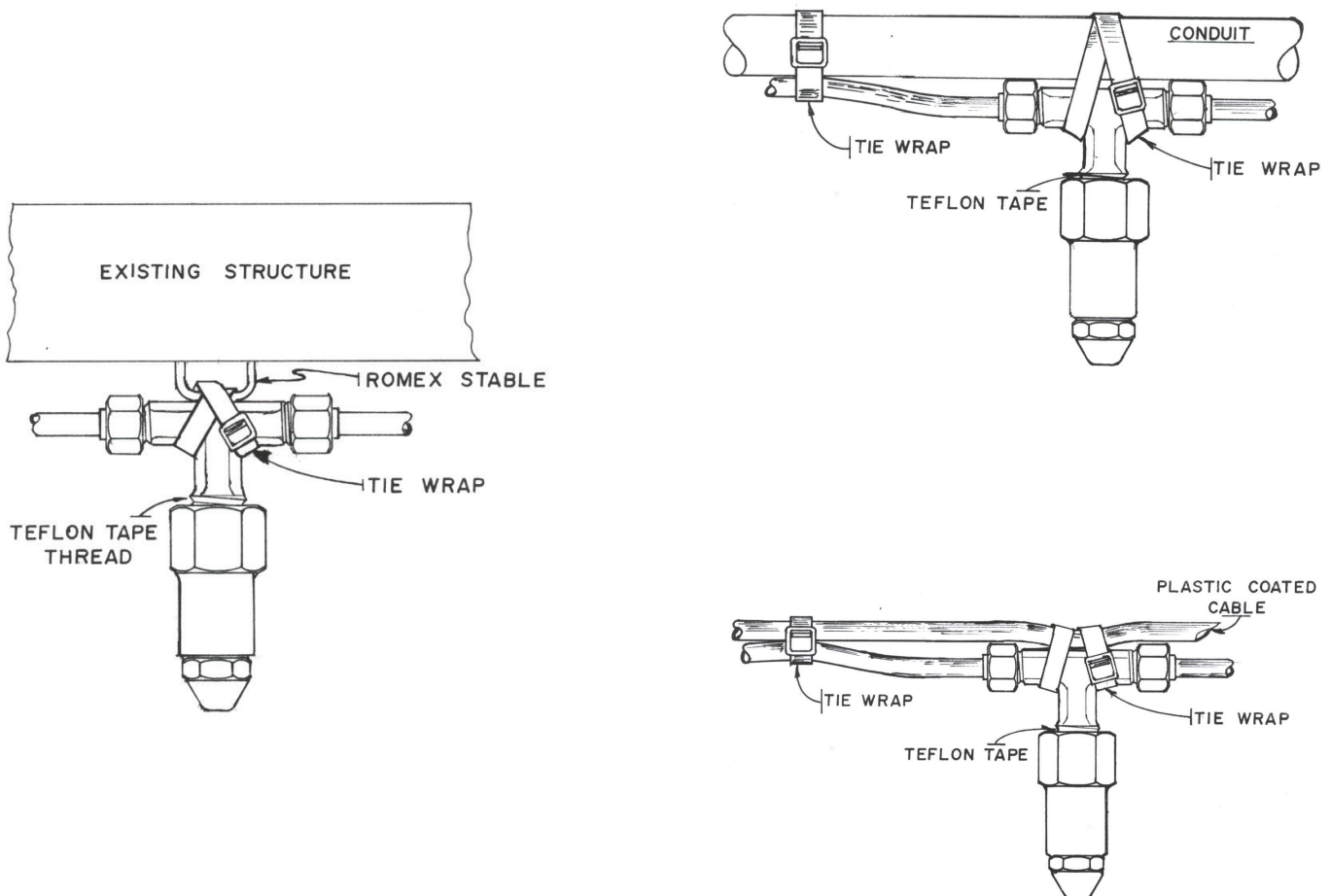

## ROUTING OF TUBING

Suggested pattern for CENTER AISLE BARN:

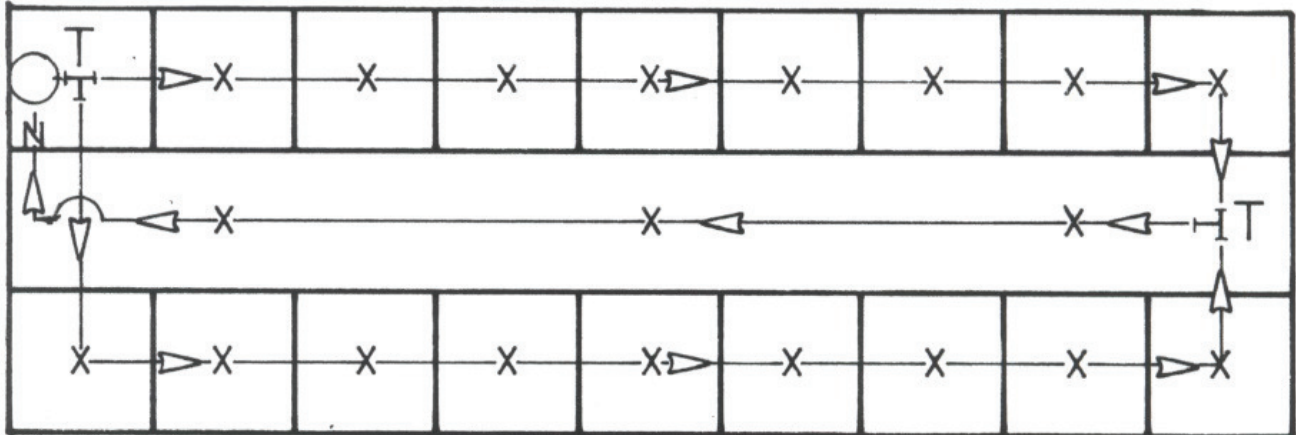

KEY:



MASTER UNIT

X NOZZLE ASSEMBLY

N 1/4" NEEDLE (BLEEDER) VALVE

T 1/4" UNION TEE

▷ DIRECTION OF FLOW

Loop the Tubing through the center of the stalls and back to the point of beginning. Connect and fasten all Nozzles in their permanent location. Using 1/4" Tubing from the Master Unit connect into the loop with a Tee. This completes your main loop.

Next, Tee into the center of the loop at the opposite end of the barn and route the Tubing along the center of the aisle, returning to the Master Unit. Do not Tee into the loop near the Master Unit. Connect and fasten all Nozzles in their permanent location. Attach the Needle (bleeder) Valve approximately 18" from the end of the Tubing in a location that is comfortable to reach so that the Lid of the Master Unit can be lifted, the end of the Tubing dropped in, and all excess fluid can be bled back into the Drum.

See page 10 for Final Setup.

See pages 15 & 16 for barns with more than 25 nozzles.

## ROUTING OF TUBING

Suggested Pattern for CENTER STALL BARN or SHEDROW BARN:

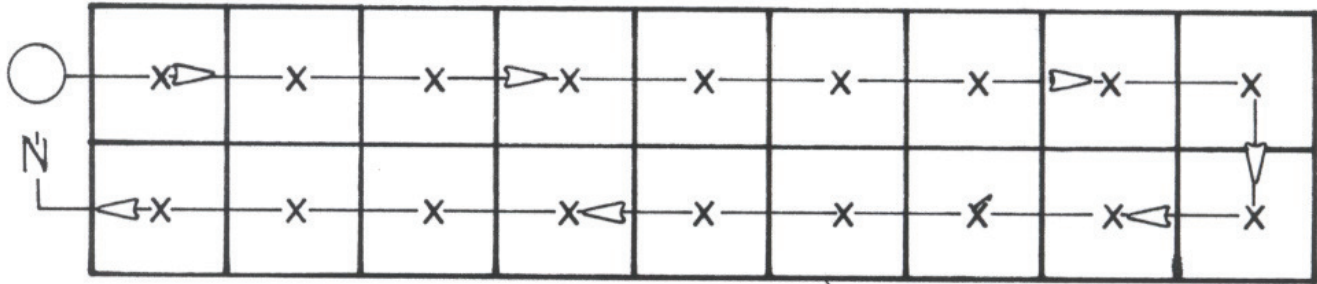

KEY:

- MASTER UNIT
- N 1/4" NEEDLE (BLEEDER) VALVE
- X NOZZLE ASSEMBLY
- ▷ DIRECTION OF FLOW

Loop the Tubing through the stalls and return to the Master Unit. Connect and fasten all Nozzles in their permanent location. Attach the Needle (bleeder) Valve approximately 18" from the end of the Tubing in a location that is comfortable to reach so that the Lid of the Master Unit can be lifted, the end of the Tubing dropped in, and all excess fluid can be bled back into the Drum.

Barns with 25 or more Nozzles:

Loop the Tubing over the stalls and return to Master Unit as described above. To finish Tubing installation and bleeding refer to Equalization of Pressure (pg. 16) and follow instructions given there.